

2006-1311: ASSESSING AND EVALUATING OUR CRCO EXPERIENCES AT THE UNIVERSITY OF CENTRAL FLORIDA: AN NSF PROJECT

Michael Georgiopoulos, University of Central Florida

MICHAEL GEORGIOPOULOS is a Professor at the School of EECS at the University of Central Florida. His research interests lie in the area of neural networks and applications. He is an Associate Editor of the IEEE Transactions on Neural Networks and the Neural Networks journal

Erol Gelenbe, Imperial College

EROL GELENBE is a Professor at the Imperial College in London, and a Research Professor at the University of Central Florida. He is a Fellow of IEEE and a Fellow of ACM. His research interests cover packet network design, computer performance analysis, artificial neural networks and simulation with enhanced reality.

Ronald DeMara, University of Central Florida

RONALD DEMARA is an Associate Professor at the School of Electrical Engineering and Computer Science at the University of Central Florida. He has been a reviewer for National Science Foundation, Journal of Parallel and Distributed Computing, IEEE Transactions on Parallel and Distributed Computing. His interests lie in the areas of Parallel and distributed processing, self-timed architectures.

Avelino Gonzalez, University of Central Florida

AVELINO GONZALEZ is a Professor of the School of Electrical Engineering and Computer Science at the University of Central Florida. He has co-authored a book entitled, "The Engineering of Knowledge-Based Systems: Theory and Practice". His research interests lie in the areas of artificial intelligence, context based behavior and representation, temporal reasoning, intelligent diagnostics and expert systems.

Marcella Kysilka, University of Central Florida

MARCELLA KYSILKA is a Professor and Assistant Chair of the Education Foundations Department at the University of Central Florida. She is active in her professional organizations and currently serves as Associate Editor of the "Journal of Curriculum and Supervision" (the scholarly journal of the Association for Supervision and Curriculum Development). Her research interests are in curriculum studies.

Mansoor Mollaghasemi, University of Central Florida

MANSOOREH MOLLAGHASEMI is an Associate Professor at the Industrial Engineering and Management Sciences (IEMS) Department at the University of Central Florida. She has co-authored three books in the area of Multiple Objective Decision Making. Her research interests lie in Simulation Modeling and Analysis, Optimization, Multiple Criteria Decision Making, Neural Networks and Scheduling.

Annie Wu, University of Central Florida

ANNIE WU is an Assistant Professor at the School of Electrical Engineering and Computer Science at the University of Central Florida. Her research interests are in the areas of genetic algorithms, machine learning, biological modeling, and visualization

Georgios Anagnostopoulos, Florida Tech

GEORGIOS ANAGNOSTOPOULOS is an Assistant Professor in the Department of Electrical and Computer Engineering at the Florida Institute of Technology. His research interests lie in the areas of Neural Networks, Machine Learning and Pattern Recognition.

Ingrid Russell, University of Hartford

INGRID RUSSELL is a Professor of Computer Science at the University of Hartford. Her research interests are in the areas of artificial neural networks, pattern recognition, semantic web technologies, and computer science education. She has been involved in several computer science curriculum projects. Most recently she chaired the Intelligent Systems focus group of the IEEE-CS/ACM Task Force on Computing Curricula 2001.

Jimmy Secretan, University of Central Florida

JIMMY SECRETAN is a Ph.D. student in the Department of Electrical and Computer Engineering at the University of Central Florida. His research interests lie in the areas of Machine Learning and cluster computing.

Assessing and Evaluating our progress on the CRCD Experiences at the University of Central Florida: An NSF Project

Abstract

Machine Learning has traditionally been a topic of research and instruction in computer science and computer engineering programs. Yet, due to its wide applicability in a variety of fields, its research use has expanded to other disciplines, such as electrical engineering, industrial engineering, civil engineering, and mechanical engineering. Currently, many undergraduate and first-year graduate students in the aforementioned fields do not have any exposure to recent research trends in Machine Learning. This paper reports on a project in progress, funded by the National Science Foundation under the program *Combined Research and Curriculum Development (CRCD)*, whose goal is to remedy this shortcoming. In the past two years, we have reported on our experiences of introducing Machine Learning modules in sophomore and junior undergraduate classes, as well as our experiences of teaching two senior level Machine Learning classes, entitled Machine Learning I and Machine Learning II. In Machine Learning I we introduce our research to the students in the class. In Machine Learning II we assign research projects to the students and we help them produce their own contributions in the Machine Learning field. One important component of our project is the assessment and evaluation of our efforts. Last spring (spring of 2005) we have invited a CRCD Advisory Board consisting of academicians, and government/industry professionals, with expertise in Machine Learning, to a 1-day CRCD Symposium at the University of Central Florida to assess and evaluate the CRCD experience. This paper reports the results of the CRCD Assessment and Evaluation conducted by the CRCD Board.

1. Introduction

In the last decade there has been an explosion of research in machine learning. A contributing factor is that traditionally independent research communities in symbolic machine learning, computational learning theory, neural networks, genetic algorithms, statistics, and pattern recognition have achieved new levels of collaboration. The outcome has been a plethora of results in machine learning emerging from all of these research communities working synergistically. The second reason for the explosive growth is that machine learning has been applied successfully to a growing range of problems in science and engineering, such as speech recognition, handwritten recognition, medical data analysis, game playing, knowledge data discovery in databases, language processing, robot control, and others.

Machine Learning has traditionally been a topic of research and instruction in computer science and computer engineering programs. Yet, due to its wide applicability in a variety of fields, its research use has expanded in other disciplines, such as electrical engineering, industrial engineering, civil engineering and mechanical engineering. Currently, quite a few undergraduate and first-year graduate students in the aforementioned fields do not have access to coursework and exposure to recent research trends in Machine Learning. The effort in this CRCD project is attempting to remedy these shortcomings. By involving in this CRCD effort a strong team of

faculty from a variety of disciplines, such as computer science, computer engineering, electrical engineering and industrial engineering with interest in Machine Learning, we hope to significantly increase the exposure of engineering and science students to machine learning technology. The faculty affiliated with the CRCD effort have significant research experience in the theory and applications of machine learning, and are therefore qualified to transfer these research experiences into the undergraduate and first-year graduate curricula.

The approach that we have chosen to integrate machine-learning research into the curriculum involves two components. The *first component* inspires student interest in machine learning, while the second component introduces the student to current research results in machine learning. The first component is realized through the incorporation of machine learning modules in sophomore and junior level coursework. One reason that we can incorporate a wide variety of interesting and inspiring machine learning modules is because of our diverse team of researchers. Hence, our goal of reaching out to a wide variety of students from several engineering disciplines will be readily accomplished. The undergraduate students enrolled in classes with machine learning modules create a good recruiting ground for attracting students to take our proposed *new* machine learning classes, the Current Topics in Machine Learning I (Machine Learning I) class, and the Current Topics in Machine Learning II (Machine Learning II) class.

These new machine-learning classes constitute the *second component* of our curriculum development efforts. The Machine Learning I class serves as the entrance point to our Machine Learning course curriculum. In this course a number of our PIs instruct the students on machine-learning techniques developed through their current research and how it relates to other machine learning approaches. The approach taken here for Machine Learning I is to have a course that is enthusiastically taught by the principal investigators (since it will always be relevant to their machine learning research), reflects the ever changing research interests of the machine learning community (the topics in this class will frequently change), and is a welcome alternative to undergraduate students (students are normally exposed to knowledge that is at least a few years old). The approach taken in Machine Learning II is to build on the fundamentals that the students have been exposed to in Machine Learning I in order to embrace the research aspects of a graspable Machine Learning project. In Machine Learning II the students have the opportunity to interact with the PIs on a one-to-one basis. This way the students are exposed to research that positively affects their critical thinking, stimulates their interest, and improves their communication skills.

In this paper we are focusing on the CRCD experiences, starting with the CRCD modules, continuing with the two Machine Learning courses, and finally observing some of the outcomes of our work that rely on the assessment and evaluation tools, as well as on progress of the students after their CRCD experiences are completed. These experiences spanned a time frame of 3 years (02-05). In particular, we invited an independent body of reviewers, consisting of researchers and educators in the field of Machine Learning, to a 1 day symposium at the University of Central Florida. Prior to attending the symposium they had the opportunity to examine some of the work that the students have completed, in addition to the results of our assessment and evaluation tools. At the symposium they were exposed to oral and poster presentations by some of the CRCD students, and they were also given the opportunity to interact with these students privately in an organized panel discussion. The specific details of the

CRCD's symposium and the feedback that the CRCD members provided are the primary focus of this paper.

3. Specifics of the CRCD Symposium

The CRCD Board members were invited to the CRCD Symposium (held on April 8, 2005 at UCF) a few months before the Symposium was supposed to take place. A month before the symposium's meeting time, a packet of information was communicated to the CRCD Board members, containing data about the CRCD Machine Learning modules, the CRCD Machine Learning I and II classes, and the Assessment and Evaluation rubrics that they were supposed to use in their assessment and evaluation process. For the CRCD Symposium we had invited seven faculty members from a variety of institutions and from the industry/government sector. Six faculty members and two industry/government sector members were able to attend the CRCD Symposium. The CRCD Symposium agenda is included in Appendix A. The CRCD rubric used for the Assessment and Evaluation of the CRCD experiences was prepared in consultation with our Assessment and Evaluation expert from the Education Department. This rubric is included in Appendix B. As it can be seen, from the rubric, the CRCD Board members were asked to assess three important elements of the CRCD experience, that is, (a) The knowledge transfer in the Machine Learning I course, (b) the process of knowledge transfer in the Machine Learning II class, (c) the CRCD dissemination potential, and (d) the CRCD approach to evaluate the project's success.

4. CRCD Preliminaries

At the beginning of the CRCD Symposium, we presented, in brief, to all the CRCD Advisory Board members an outline of the CRCD project. In particular, we presented information about the CRCD's goals, the CRCD's principal investigators and their interests, CRCD's long term vision, CRCD's accomplishments in terms of education outreach, and ideas, and finally we emphasized CRCD's current dissemination efforts to other institutions, as well as its future at UCF or potentially other institutions.

For instance it was pointed out that 10 students have been involved in Machine Learning I and II courses in the 03-04 and 04-05 academic, years respectively. In particular, from the students that presented their projects in the CRCD Symposium (see Section 5 for a list of CRCD projects at the symposium), the student of Project CRCD-A is currently pursuing his Masters in the Computer Engineering Department at the University of Central Florida, the student of Project CRCD-B is currently working at a nearby to UCF industry, the student of Project CRCD-C is an NSF graduate fellow pursuing his Ph.D. degree in the Computer Engineering Department at the University of Central Florida, one of the three students in Project CRCD-D is pursuing his Masters degree in the Computer Engineering program at the University of Central Florida, while the other two found employment in nearby industry and government sectors, the three students in Project CRCD-E have found employment in nearby to UCF industries, the student in Project CRCD-F is pursuing his Ph.D. degree in the Computer Engineering program at UCF, the student in Project CRCD-G is pursuing his Ph.D. degree in the Computer Engineering program at UCF, and finally in Project CRCD-H one student is pursuing his Masters in the Electrical Engineering

program at UCF, while the other one is pursuing his Ph.D. in the Computer Science program at UCF.

The work of Project CRCD-A was published in a conference venue⁸. The work of Project CRCD-B was published in a conference venue¹², is under review in another conference venue¹³ and is also under review in a journal venue¹³. The work of Project CRCD-C was published in a conference venue³, was also published in a journal venue⁴, and is currently under review in another journal venue⁵. The work in Project CRCD-D was published in a conference venue (winning best paper award), and is under review in another conference venue¹⁵ and in a journal venue¹³. The work in Project CRCD-E was published in two conference venues^{10, 11}. The work in Project CRCD-F is a Ph.D. thesis in progress and will produce the appropriate publications in time.

5. The Oral and Poster Presentations

Eight of our CRCD projects, conducted in the academic years 03-04 and 04-05, were presented during the CRCD symposium. More specifically, a short oral presentation of each one of these projects was presented by the corresponding students or student groups, in the first part of the a.m. portion of the Symposium, while the poster presentations were presented in the second part of the a.m. portion of the Symposium (see agenda in Appendix A for more details). The purpose of the oral presentation was for the CRCD Board members to understand the basics of the projects, while the purpose of the poster session was to be exposed to the details of each project and have the opportunity to learn more about the projects by interacting one-to-one with the CRCD students. The titles of the projects that were presented at the symposium were as follows:

1. **CRCD-A Project:** Hilbert Space Filling Curve Nearest Neighbor Classifier (one student)
2. **CRCD-B Project:** Experiments with Safe μ ARTMAP (one student)
3. **CRCD-C Project:** Pipelining of Fuzzy ARTMAP without Match-Tracking (one student)
4. **CRCD-D Project:** Experiments with the Probabilistic Neural Network – Implementation on a Beowulf Cluster (three students)
5. **CRCD-E Project:** Experiments with ART Neural Networks – Implementation on a Beowulf Cluster (one student)
6. **CRCD-F Project:** Contextualizing Observational Data (one student)
7. **CRCD-G Project:** gNNCAD: Gary's Neural Network Classifier and Driver (one student)
8. **CRCD-H Project:** Evolving Control for Distributed Micro Aerial Vehicles (two students)

Specifically, we provide details about one of these projects that was presented in the CRCD symposium.

CRCD-C Project: Pipelining of Fuzzy ARTMAP without Match-Tracking

This project deals with the issue of parallelizing in a pipeline, a popular neural network architecture, referred to as Fuzzy ARTMAP (FAM). The Adaptive Resonance Theory (ART) was developed by Grossberg⁷, and Fuzzy ARTMAP⁶, one of its most prominent representatives, has been successfully used in the literature for solving a variety of classification problems. Some of the advantages of FAM, that are worth mentioning are its guaranteed convergence to a solution for any classification problem, its fast convergence to a solution, its capability to learn

the data on-line, its novelty detection feature that notifies the user when it is confronted with novel (not previously seen) inputs, its ability to explain the answers that it produces, and of course its proven (throughout the years) potential of effectively solving classification problems from a variety of application disciplines.

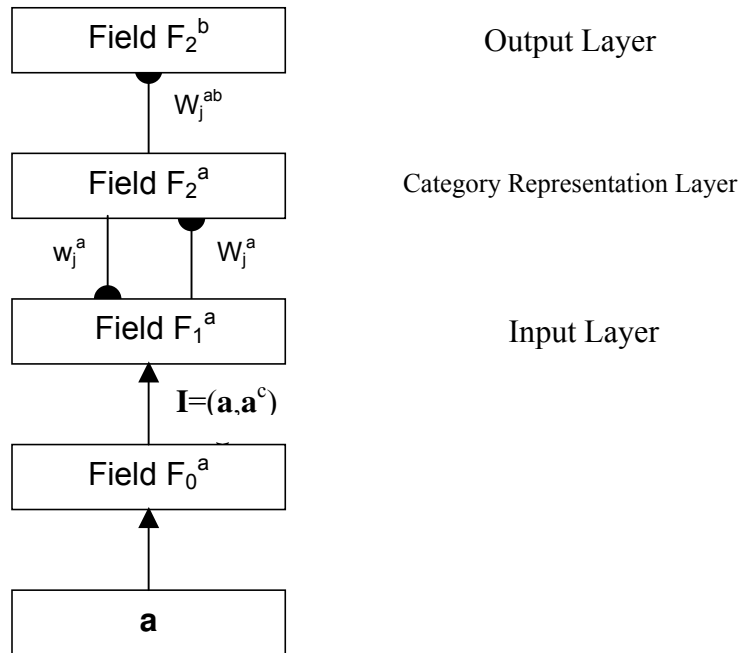

Figure 1: A block Diagram of the Fuzzy ARTMAP Architecture

In order to better understand the project that the CRCSD student has been involved with, we present some background information regarding the FAM architecture. The FAM architecture is a layered neural network architecture, and it called as such because nodes (neurons) in this architecture are organized in layers. In particular, the FAM consists of three layers or fields of nodes (see Figure 1). These layers are the *input layer* (F_1^a), the *category representation layer* (F_2^a), and the *output layer* (F_2^b). The input layer is the layer where the input data are presented to FAM. The category representation layer of FAM is where categories (or groups) of input patterns are formed (or compressed representations of the input patterns are formed). Finally, the output layer of FAM is the layer that produces the outputs of the network. Every node of the output layer represents a distinct label (output) of the problem at hand. FAM forms compressed representations of the input patterns at the category representation layer and these compressed representations are mapped to the appropriate labels at the output layer.

The number of nodes in the category representation layer of FAM is the number that characterizes the size of the FAM architecture. A node (category) of layer F_2^a has a vector of weights associated with it. This vector of weights is called a *template* and it has an interesting geometrical interpretation. All the input patterns that choose and are coded by a specific node in the category representation layer of FAM have their components enclosed within a rectangular region (hyper-rectangular region in more than two dimensions). This rectangular region is

uniquely defined by its lower and upper endpoints. The values of the lower and upper endpoints concatenated together constitute the value of the weight vector associated with this node. For illustration purposes see Figure 2 where 5 patterns are shown as coded by a specific category node of FAM, whose rectangular representation is also depicted. It is worth noting that the rectangle corresponding to a weight vector of a FAM category representation layer node is the smallest rectangle, with sides parallel to the coordinate axes, that includes within its boundaries the input patterns, coded by this node. The geometrical interpretation of the weights of the category representation layer in FAM allows us to quickly understand the FAM learning process. If an input pattern is presented to FAM and is coded by a node, whose rectangular representation includes within its boundaries this input pattern, no learning occurs (see Figure 3 for an illustration of this case). If on the other hand an input pattern is coded by a node, whose rectangular representation does not include the pattern, then during FAM's learning the rectangle boundaries are expanded to include it (for an illustration of this case see Figure 3).

The project assigned to the student in the Machine Learning II class dealt with the implementation of a Fuzzy ARTMAP variant (called no-match tracking FAM) on a Beowulf cluster. One of the reasons that such an implementation is important is because Fuzzy ARTMAP, despite its impressive convergence to a solution (i.e., it takes only a few iterations through the training data to converge to a solution) slows down considerably when the size of the training set is large, as it is usually the case in a number of data-mining applications. To remedy this shortcoming, this project focused on an efficient, parallel implementation of the no-match

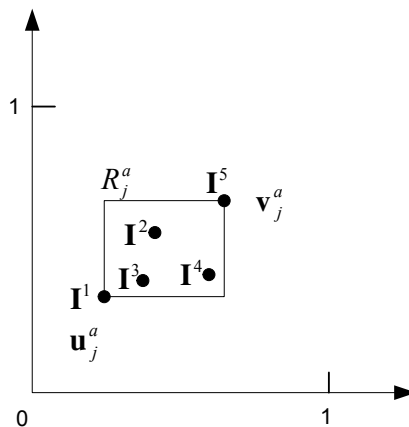

Figure 2: A FAM category that learned 5 patterns, is represented by two vectors \mathbf{u}_j^a and \mathbf{v}_j^a .

tracking FAM algorithm on a cluster of workstations (Beowulf cluster). In this work, the CRCSD student, in close collaboration with a Ph.D. student, proposed an implementation, and demonstrated its good properties theoretically (theorems were postulated and proved) and through experimentation (the parallel algorithm was tested on a number of large datasets). In particular, the no-match tracking FAM was tested on a real-database (Forrest Coverttype database from the UCI repository) and on simulated databases (Gaussianly distributed data belonging to

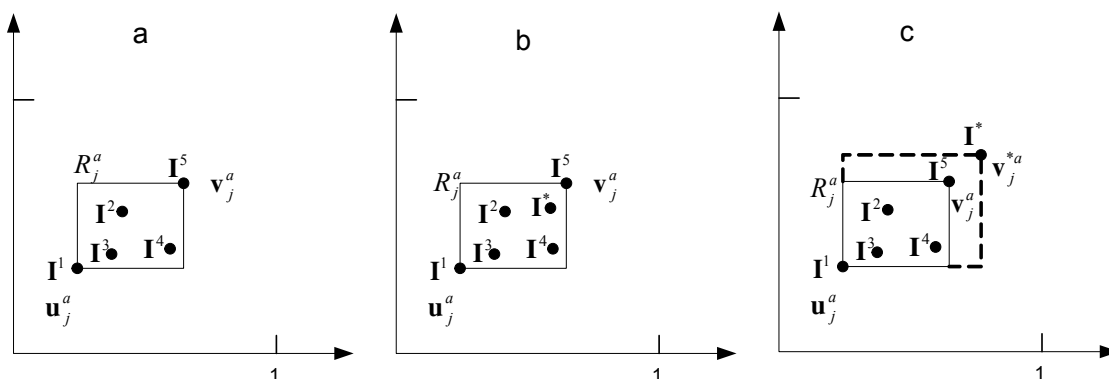

Figure 3: FAM Learning: **a.** A FAM category that learned 5 patterns. **b.** A new pattern I^* was presented inside the category, and thus a category does not expand. **c.** A new input pattern I^* was presented outside the category, and thus the category expands to include the input pattern.

two different classes). The results on the Forrest Coverttype database are shown in Figure 4. In this figure the speed-up attained by the parallel no-match tracking FAM compared to the sequential no-match tracking FAM implementation is depicted. The speed-up (shown in Figure 4) is demonstrated for training set sizes ranging from 32,000 patterns to 512,000 patterns (in steps of powers of 2), and for 1, 2, 4, 8, 16, and 32 processors of the Beowulf cluster. An obvious observation from this figure is that speed-up achieved using the parallel no-match tracking FAM grows linearly with the number of processors in the Beowulf cluster.

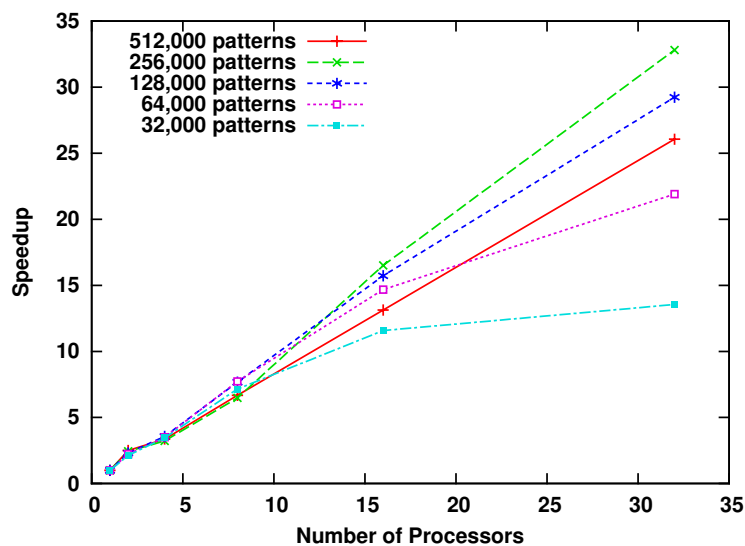

Figure 4: Speed-up performance of the no-match tracking FAM for the CoverType database for different pipeline sizes (1 through 32 in steps of 2) and different database sizes (32,000 to 512,000 in steps of power of 2).

The no-match tracking FAM is a variation of the FAM neural network architecture, where when the time comes for FAM to implement the match tracking mechanism⁶, no-match tracking FAM chooses a new category in the category representation layer of Fuzzy ARTMAP. No match

tracking FAM has been introduced by Anagnostopoulos and his colleagues¹ and has been shown to attain better accuracy than FAM at the expense of creating more categories during the FAM's training process. The reason that we chose in this project to parallelize no-match tracking FAM is because the parallelization of FAM is a much more complex process.

6. The Panel Discussion: CRCD Board and CRCD Students

As the CRCD agenda indicates (see Appendix A) we had planned an interaction between the CRCD students and the CRCD Advisory Board members immediately after the completion of the CRCD oral presentations. We provided the CRCD Advisory Board members with a list of questions that we wanted them to ask the CRCD students (see below).

Questions for the CRCD Board Panelists to Ask the CRCD Students

1. How do you think the projects helped you to understand the concepts you were expected to know?
2. What advice would you give your professors to improve the projects?
3. What advice would you give your professors to improve the course?
4. What recruitment strategies were used to get you interested in this program?
5. What suggestions do you have for other forms of recruitment?
6. Did participation in this program increase/decrease your interest in machine learning?

It turned out that the discussion between the CRCD students and the panelists took more of the form of a freelance discussion and exchange of information. We are reporting the results of this conversation in a rather unorthodox fashion without any effort to categorize the questions and answers into groups. To preserve the anonymity of the CRCD Board members we will refer to them with their first names.

Silvano asked whether the transition from Machine Learning I to Machine Learning II was reasonable, and the CRCD students responded that it was, and that they liked the idea of the “2-week format” in Machine Learning II, where students were exposed to potential CRCD projects before projects were assigned. Mike asked how rewarding the project experience in Machine Learning II has been and the students responded that once they started getting tangible results the experience becomes rewarding quickly. Silvano asked whether the students would go back to Machine Learning I and II classes to learn more things but the answer was no, in the sense that these two classes serve as feeders to other Machine Learning graduate classes and there is no need to re-visit them. Christos asked who did they learn more from, the CRCD professor or the CRCD graduate student, and the answer was both, in the sense that each one of them served his/her role, the professor giving guidance about the project and the graduate students resolving any difficulties throughout the project's implementation. Christos asked how they were recruited to the Machine Learning classes and some of the students responded because of the modules, others because of the marketing of the course in the Honors College. Christos asked whether they

chose a topic based on subject or instructor, and all of them replied that the topic was the drawing factor. Mike asked whether it was hard to figure out the ground rules in the 2-weeks prior to the selection of projects in Machine Learning II, and the answers were no. Christos asked about the deadlines imposed for the completion of the Machine Learning II and the students responded that there are no hard deadlines. The students responded that they were given the option to finish at the end of the semester or continue the research in future semesters, and all of them liked this flexibility. Christos asked if the students learned how to do literature review and the students responded that after they were given some initial papers to review and detailed information of how to do literature review, they were left on their own devices to provide additional references. The students also added that there was a learning curve until they got accustomed to the terminology of the papers. George asked how the groups were formed in the cases of group CRCD projects. The students responded that the groups formed naturally, based on friendships and acquaintances established from their earlier years in college. The professors did not force any groupings. With respect to effective recruiting strategies the students suggested that we should more aggressively advertise the class in the Computer Science-3 course (that CS students take), and we should continue advertising CRCD through the CRCD modules. The students also indicated that it is a good idea to have paper competition with an award, or DARPA-like competitions amongst all the CRCD students.

7. The Interaction between CRCD PIs and CRCD Board

At the end of CRCD Symposium, the CRCD PIs met with the CRCD Advisory Board to hear their comments regarding the CRCD experience, after they have had a day long interaction with CRCD students. They pointed out that some of the unique things about the CRCD project at UCF are that there is a successful team-teaching process in Machine Learning I, and that CRCD students are self-motivated to do the Machine Learning project work. They pointed out though that the brunt of the CRCD work falls on the shoulders of few of the CRCD PIs, and if these PIs were missing, CRCD would have a hard time to proceed without them.

The cumulative responses of the CRCD Advisory Board to the questions in the Assessment and Evaluation rubric are listed in the following figure (Figure 5). The horizontal axis of the graph corresponds to 1 of the 11 questions asked. The answers to each question were: Excellent, Good, Adequate, and Poor. In the figure, the dark blue bar corresponds to the number of responses that were excellent the light blue corresponds to the number of responses that were good and the yellow bar corresponds to the responses that were adequate for the question under consideration. To simplify the graph (see Figure 5) in questions 8 and 10 of the rubric that had multiple sub-questions, we provided as an answer in the graph the answer that was most often chosen by the Board members.

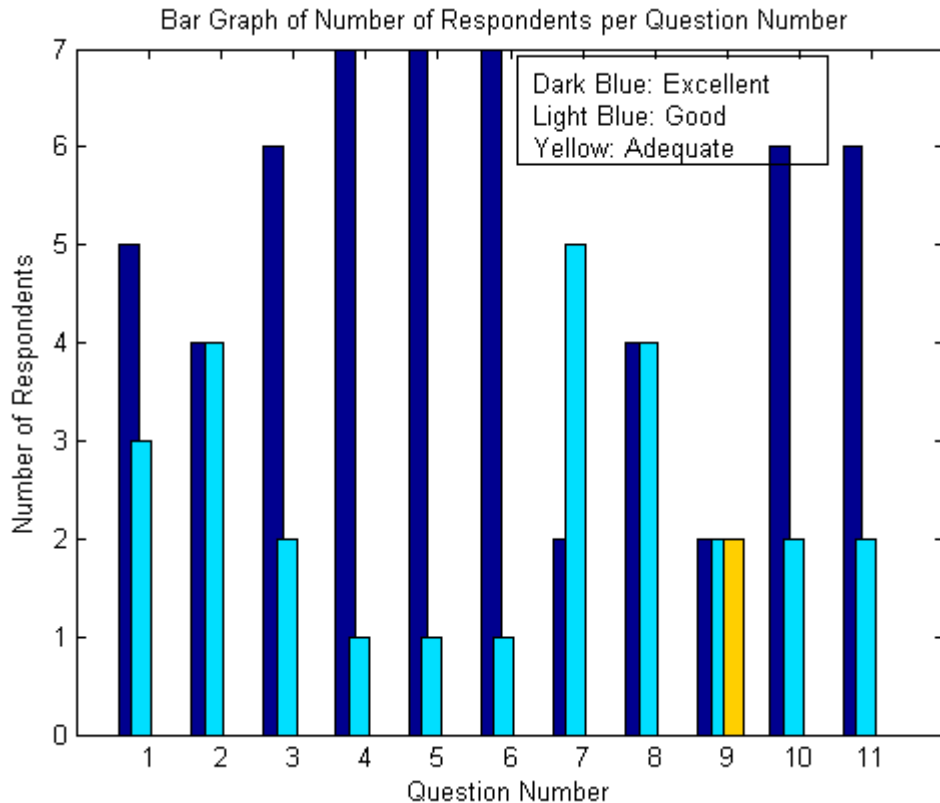

Figure 5: A bar graph of responses of the CRCD Advisory Board Members to each one of the 11 questions included in the CRCD Assessment and Evaluation rubric. Dark blue corresponds to a response “Excellent”, the light blue corresponds to a response “Good” and the yellow corresponds to a response “Adequate”. The statements of Questions 1-11 are included in Appendix B.

8. Dissemination Efforts

Each one of the members of the CRCD Advisory Board was asked the following question: What do you think the chances are that a project similar to CRCD could be implemented at your school. This was Question 9 of the questionnaire. Two of the respondents replied “excellent”, two of the respondents replied “good”, and two of the respondents replied “adequate”. The remaining two respondents did not reply because they were representing members from the industry/government and as a result this question was not applicable to their case.

From the responses it seems that the CRCD Advisory Board members found that the dissemination potential of CRCD is good. Actually, two of the CRCD Advisory Board members have found ways to disseminate CRCD to their corresponding institutions, in a format that fits the special characteristics of their institutions.

In particular, CRCD has been disseminated to the University of Hartford, Central Connecticut State University and Gettysburg College through an NSF CCLI A@I grant that Dr. Ingrid Russell from the University of Hartford has obtained in collaboration with colleagues from the Central Connecticut State University and Gettysburg College. The CCLI NSF grant obtained by the University of Hartford is entitled “Machine Learning Laboratory Experiences for Introducing

Undergraduates to Artificial Intelligence”. The goals of this grant are: (a) Highlight the bridge that machine learning provides between AI and modern software engineering, and (b) Introduce students to an increasingly important research area, thus motivating them to pursue research in this area⁹. It is worth pointing out that the dissemination potential of Dr. Russell’s CCLI A&I grant is excellent, since she has involved many other institutions in her CCLI A&I effort as immediate recipients of the produced educational materials and practices.

Furthermore, CRCD has been disseminated to the Florida Institute of Technology through a CCLI NSF grant that Georgios Anagnostopoulos has obtained². The title of this prototype grant is “Project EMD-MLR: Educational Materials Development and Research in Machine Learning for Undergraduate students”. The purpose of this grant is to involve senior design students in Machine Learning research. In the process of doing so, educational materials in Machine Learning are developed, such as Machine Learning code, Machine Learning notes, etc. This grant also involved two community colleges (Seminole Community College and Brevard Community College). It is worth noting that the extension of this grant plans (full development phase that Dr. Anagnostopoulos is competing for in the CCLI 06 cycle) involves other Universities in this educational activity, and consequently disseminates educational Machine Learning materials and practices to other Universities too. The Universities that Dr. Anagnostopoulos has involved are: University of New Mexico, Florida State University, University of Nevada, and University of New Orleans.

Hence, it has been a successful CRCD practice to disseminate CRCD to other institutions (in a modified format) by simply influencing other colleagues, who have been involved as CRCD Advisory Board members, to disseminate some of the CRCD ideas and practices to their host institutions.

9. Discussion/Lessons Learned

We have reported in this paper the Assessment and Evaluation results obtained from an independent group of academicians and researchers with an interest in Machine Learning. This group constituted the CRCD Advisory Board and they were gracious enough to visit UCF in the spring of 2005, meet with a number of CRCD students during their visit, attend an oral and a poster presentation, and engage students in a panel discussion. Based on this interaction and additional information that was provided to them, they were able to assess and evaluate the CRCD experiences.

The results of their evaluation are pictorially illustrated in Figure 5. The questions that they have answered are included in a rubric, delineated in Appendix B.

In review, the CRCD Board did not find any serious flaws with the material covered in Machine Learning I, or in how much of this material was transferred to the CRCD students. The Board members did not find any serious flaws with the process of performing research in the Machine Learning II class either. Furthermore, they thought that recruiting through CRCD modules, guest lectures, word of mouth and personal interactions with students were sufficient recruiting strategies to attract students to perform research in Machine Learning. They also thought that the ways that we assess and evaluate the CRCD experiences are appropriate in getting enough and useful feedback about the goodness of our methods/practices.

One of the issues that were raised throughout the CRCD Advisory Board Symposium was the issue of continuing this CRCD effort, after NSF funding expires. In particular, it was suggested that after the grant expires there should be a team of 3 “permanent” professors that consistently teach the Machine Learning courses. However an effort needs to be made to bring another team of professors (a number of 3 “rotating” professors was suggested) to this group of permanent professors. The “rotating” group of professors will bring new ideas to the project and will also help share the load.

References

1. Anagnostopoulos, G. C., and Georgiopoulos, M. “Putting the utility of match-tracking in Fuzzy ARTMAP to the test,” In *Proceedings of the Seventh International Conference on Knowledge-Based Intelligent Information (KES)*, London, England, 2003
2. Anagnostopoulos, G. C., Georgiopoulos, M., Ports, K., Richie, S., Cardinale, N., White, M., Kepuska, V., Chan, P.K., Wu, A., Kysilka, M., “Project EMD-MLR: Educational Materials Development and Research in Machine Learning for Undergraduate students,” *Proceedings of the ASEE 2005 Annual Conference and Exposition*, Session 3232, Capstone & Educational Resource Developments, June 12-15, Portland, Oregon, 2005.
3. Castro, J., Secretan, J.(*), Georgiopoulos, M., DeMara, R. F., Anagnostopoulos, G., and Gonzalez, A., “Pipelining of Fuzzy ARTMAP (FAM) without match-tracking,” *Intelligent Engineering Systems Through Artificial Neural Networks: Smart Engineering System Design: Neural Networks, Fuzzy Logic, Evolutionary Programming, Complex Systems and Artificial Life*, Volume 14, edited by C. H. Dagli, A. L. Buczak, D. L. Enke, M. Embrechts, and O. Ersoy, 2004, ASME Press Series, pp. 69-74; presented at the ANNIE 2004 conference in St. Louis, MI, November 2004.
4. Castro J. Georgiopoulos, M., Secretan, J.(*), DeMara, R., Anagnostopoulos, G., and Gonzalez, A., “Parallelization of Fuzzy ARTMAP to improve its convergence speed: The network partitioning approach and the data partitioning approach”, *Nonlinear Analysis*, Volume 63, Issues 5-7, 30 November 2005c-15 December 2005c, pages e877-e889.
5. J. Castro, J., Secretan, J.(*), Georgiopoulos, M., DeMara, R., Anagnostopoulos, G., and Gonzalez, A., “Pipelining of Fuzzy ARTMAP without Match-Tracking: Correctness, Performance Bound, and Beowulf Evaluation,” *Neural Networks*, under review, 2006.
6. Carpenter, G. A., Grossberg, S., Markuzon, N., Reynolds, J., and Rosen, D. B., “Fuzzy ARTMAP: A neural network architecture for incremental supervised learning of analog multi-dimensional maps,” *IEEE Transactions on Neural Networks*, Vol. 3, pp. 698-713, 1992.
7. Grossberg, S., “Adaptive pattern classification and universal recoding I: Parallel development and coding of neural feature detectors,” *Biological Cybernetics*, Vol. 23, pp. 121-134, 1976.
8. Reeder J.(*), Georgiopoulos, M., Castro, J., Anagnostopoulos, G., and Mollaghasemi, M., “Hilbert Space Filling Curve Nearest Neighbor,” *The ISAS and CITSA 2005*, July 14-17, 2005, Orlando, FL, pp. 273-278.
9. Russell, I., Markov, Z., Neller, T., and Georgiopoulos, M., “Machine Learning laboratory experiences for introducing undergraduates to Artificial Intelligence,” *Proceedings of the ASEE 2005 Annual Conference and Exposition*, Session 1793, Emerging Trends in Engineering Education, June 2-15, Portland, Oregon, 2005.

10. Secretan J., Castro, J., Chadha, A.(*), Huber, B.(*), Tapia, J.(*), Georgiopoulos, M., Anagnostopoulos, G., and Richie, S., "Pipelining of ART architectures (FAM, EAM, GAM) without match-tracking (MT)," *2005 Artificial Neural Networks in Engineering (ANNIE 2005)*, St. Louis, MI, , November 2005.
11. Secretan J., Castro, J.(*), Chadha, A. (*), Huber, B. (*), Tapia, J. (*), Georgiopoulos, M.(*), Anagnostopoulos, G., and Richie, S., "Pipelining of Fuzzy ARTMAP (FAM) for data mining applications," *2005 International Joint Conference on Neural Networks*, Montreal, Quebec, July 31- August 4, 2005.
12. Zhong, M., Rosander, B.(*), Georgiopoulos, M., Anagnostopoulos, G., and Mollaghasemi, M., "Experiments with Micro-ARTMAP: Effect of the Network Parameters on the Network Performance," *2005 Artificial Neural Networks in Engineering (ANNIE 2005)*, St. Louis, MI, November 2005.
13. Zhong, M., Rosander, B.(*), Georgiopoulos, M., Anagnostopoulos, G., Mollaghasemi, M., and Richie, S., "Experiments with Micro-ARTMAP: Effect of the Network Parameters on the Network Performance," *WCCI 2006*, under review and *Neural Networks journal*, under review, 2006.
14. Zhong, M., Hecker, J.(*), Maidhoff, I.(*), Shibly, P.(*), Georgiopoulos, M., Anagnostopoulos, G., and Mollaghasemi, M., "Probabilistic Neural Network: Comparisons of the Cross-Validation Approach and a Fast Heuristic to choose the Smoothing Parameters," *2005 Artificial Neural Networks in Engineering (ANNIE 2005)*, St. Louis, MI, November 2005.
15. Zhong, M., Hecker, J.(*), Maidhoff, I.(*), Shibly, P.(*), Georgiopoulos, M., Anagnostopoulos, G., and Mollaghasemi, M., "Probabilistic Neural Network: Comparisons of the Cross-Validation Approach and a Fast Heuristic to choose the Smoothing Parameters," *WCCI 2006*, under review and *Neural Networks journal*, under review, 2006.

Note: Undergraduate students in the above publications are designated with an asterisk.

Appendix A: Agenda of the CRCDD Symposium

CRCDD Symposium Agenda April 8, 2005

1. 8:00 – 8:30 a.m. Setting up of the CRCDD Posters (CL1-Room 103; CRCDD Students)
2. 8:30 – 9:00 a.m. Breakfast, Introductions (CL1-Room 103; all)
3. 9:00 a.m. – 9:10 a.m. CRCDD Overview (CL1-Room 103; all)
4. 9:10 a.m. – 10:15 a.m. CRCDD Oral Presentations (CL1-Room 103; CRCDD Students)
 - a. CRCDD-A Project: Hilbert Space Filling Curve Nearest Neighbor Classifier
 - b. CRCDD-B Project: Experiments with Safe μ ARTMAP
 - c. CRCDD-C Project: Pipelining of Fuzzy ARTMAP without Match-Tracking
 - d. CRCDD-D Project: Experiments with the Probabilistic Neural Network – Implementation on a Beowulf Cluster
 - e. CRCDD-E Project: Experiments with ART Neural Networks – Implementation on a Beowulf Cluster
 - f. CRCDD-F Project: Contextualizing Observational Data
 - g. CRCDD-G Project: gNNCAD: Gary's Neural Network Classifier and Driver
 - h. CRCDD-H Project: Evolving Control for Distributed Micro Aerial Vehicles (MAVs)
5. 10:15 a.m. – 10:30 a.m. Short Coffee Break; Poster Set-Up (CL1-Room 103; all)
6. 10:30 a.m. – 11:45 a.m. CRCDD Poster Presentations (CL1-Room 103; CRCDD Students)
 - a. CRCDD-A Project: Hilbert Space Filling Curve Nearest Neighbor Classifier
 - b. CRCDD-B Project: Experiments with Safe μ ARTMAP
 - c. CRCDD-C Project: Pipelining of Fuzzy ARTMAP without Match-Tracking
 - d. CRCDD-D Project: Experiments with the Probabilistic Neural Network – Implementation on a Beowulf Cluster
 - e. CRCDD-E Project: Experiments with ART Neural Networks – Implementation on a Beowulf Cluster
 - f. CRCDD-F Project: Contextualizing Observational Data
 - g. CRCDD-G Project: gNNCAD: Gary's Neural Network Classifier and Driver
 - h. CRCDD-H Project: Evolving Control for Distributed Micro Aerial Vehicles (MAVs)
7. 11:45 a.m. – 1:00 p.m. Lunch (at UCF; all)
8. 1:15 p.m. – 2:15 p.m. CRCDD Panel Discussion (Engineering 1, room 224; CRCDD Board and Students)
9. 2:15 p.m. – 2:30 p.m. Short Coffee Break (Engineering 1, room 224; all)
10. 2:30 p.m. – 3:00 p.m. CRCDD Evaluation by CRCDD Board Members (Engineering 1, room 224; CRCDD Board Members)
11. 3:00 p.m. – 3:30 p.m. CRCDD Board Chair's Report (Engineering 1, room 224; CRCDD Board Chair to CRCDD PIs)
12. 3:30 p.m. – 4:00 p.m. Coffee; Discussions of Extending CRCDD Dissemination Efforts (Engineering 1, room 224; all)

Note: CL-1 is Classroom Building 1

7:30 p.m. Dinner at the Olympia Restaurant (all interested parties)

Appendix B: Assessment and Evaluation CRCD Advisory Board Member Rubric

1st CRCD Symposium
April 8, 2005
CRCD Project Evaluation

The purpose of this rubric is to provide us with feedback as to your perceptions of the knowledge acquisition and transfer of the CRCD students, our recruiting efforts, our dissemination concerns and our overall evaluation strategies. Please be candid with your responses.

Directions: Circle the number that best indicates your perceptions.

1 = excellent; 2= good; 3= adequate; 4= poor

Knowledge transfer of CTML-1 class (lecture oriented)

1. Examining the results of the student questionnaires for CTML-1, what is your perception of their knowledge acquisition and transfer? 1 2 3 4
2. Based on the corrected homework and examinations for CTML-1 students, what is your perception of their knowledge acquisition and transfer? 1 2 3 4
3. What is your perception of the appropriateness of the material taught in CTML-1 for the academic level of the students? 1 2 3 4

Suggestions for improving the content and/or processes used to assess students' knowledge.

Process of Knowledge Transfer for CTML-II class (project oriented)

4. Based on the information provided and the feedback from the CRCD students, how would you rate the quality of the topics they pursued? 1 2 3 4
5. Based on the information provided and the feedback from the CRCD students, how would you rate the project method as a process for knowledge acquisition and transfer? 1 2 3 4
6. Based on the feedback you received from the CRCD students and the oral and poster presentations, how would you rate the knowledge acquisition and transfer of the students throughout the project experience? 1 2 3 4

Suggestions for improving the CTML-II classes, e.g., projects assigned, processes of assessing student knowledge, etc.

Recruitment

7. Based upon the information provided to you, what are your perceptions of the effectiveness of the recruiting strategies of the CRCDD modules? 1 2 3 4
8. Based on the information provided to you, what are your perceptions of the effectiveness of the recruiting through the use of:
- a. CRCDD modules 1 2 3 4
 - b. Guest lecturers 1 2 3 4
 - c. Word of mouth 1 2 3 4
 - d. Personal interaction with CRCDD PIs 1 2 3 4
 - e. Other (identify)_____ 1 2 3 4

Please suggest other recruiting strategies that might be used for projects similar to CRCDD.

Dissemination

9. What do you think the chances of a project similar to CRCDD could be implemented at your school? 1 2 3 4

What challenges would you face in implementing such a project?

How could these be overcome?

Project Evaluation

10. What is your perception of our attempts to evaluate student learning:
- a. homeworks 1 2 3 4
 - b. examinations 1 2 3 4
 - c. projects 1 2 3 4

- d. presentations 1 2 3 4
- e. interactions with faculty/experts 1 2 3 4

11. What is your perception of our attempts to evaluate the entire project? 1 2 3 4

Suggestions for improvements